

## Fast Test Sub

*The Phuel Fast Test Sub saves rig time when it's necessary to make and break the lubricator to install and remove the tool string several times. The Fast Test Sub connection can be tested after make-up without filling and testing the whole lubricator string, greatly reducing operation time.*



The Fast Test Sub body is constructed in two parts connected by a quick union collar. When the collar is backed off, the two parts can be separated to break into the riser string. When re-connected, applying pressure between the two O-ring seals proves the pressure integrity again and allows operations to continue. The test connection is isolated after use by means of a single isolation valve incorporated into the bottom sub.

A range of useful features that make handling and operation faster and safer differentiates the Phuel Fast Test sub from others currently on the market.



### **Inverted O-Rings**

It is now easier to stab in the upper lubricator section and cope with greater misalignment without damaging the O-rings as they are now mounted in the lower box section. This ensures that they are not touched until the nose of the connection has been almost fully made up. The size of the O-rings is also the same as those on the end connections.

### **Safe Lok Collar**

The Safe Lok system automatically supports the weight of the collar while stabbing in, removing unnecessary handling and reducing the risk of personal injury.

### **Saver Sub**

The saver sub provides the pressure test connection, and can be easily removed and replaced in the event of damage without the need to change the bottom sub. This ensures that the tool stays in service longer.

*The Phuel Fast Test Sub is available with the most common end connections for operating pressures of 10,000 psi. Contact us for more details.*



**A FLEXIBLE  
APPROACH,  
IMPROVED SAFETY  
AND EFFICIENCY  
THROUGH DESIGN**

**Phuel Oil Tools Ltd**  
Unit 17  
Denmore Industrial Estate  
Denmore Rd  
Bridge of Don  
Aberdeen AB23 8JW

Tel: 01224 820 016  
info@phueloiltools.com

**www.phueloiltools.com**

# Fast Test Sub

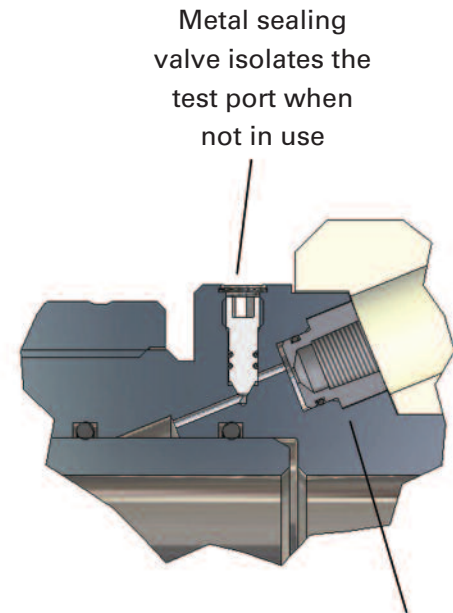
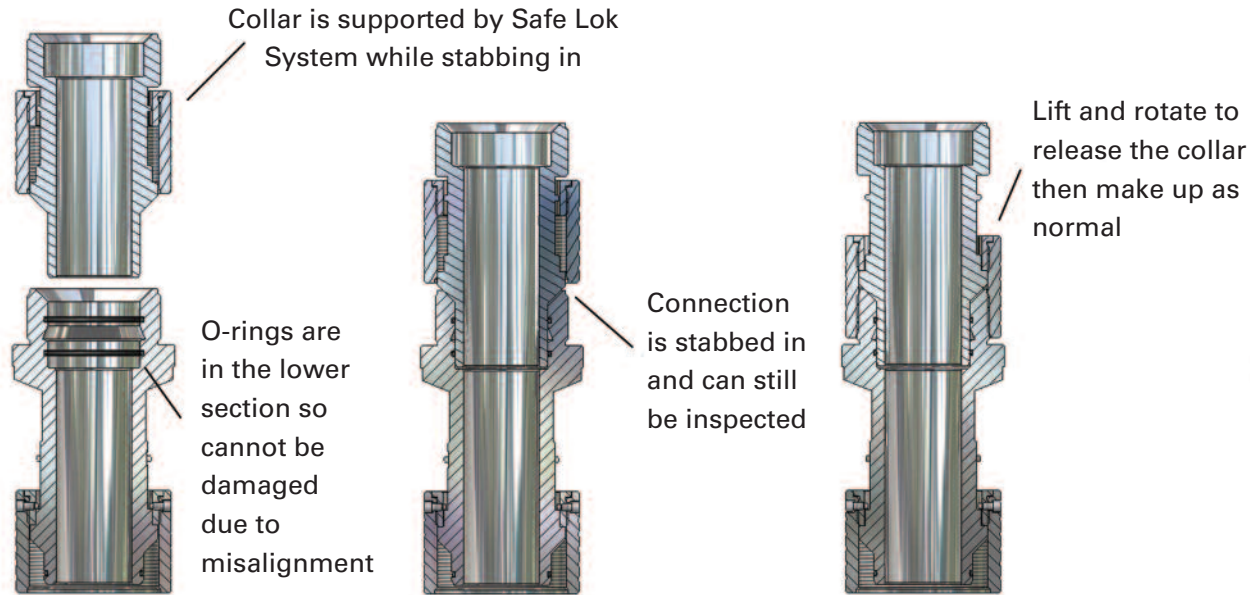

Industry standard end connections to suit your requirements and pressure rating

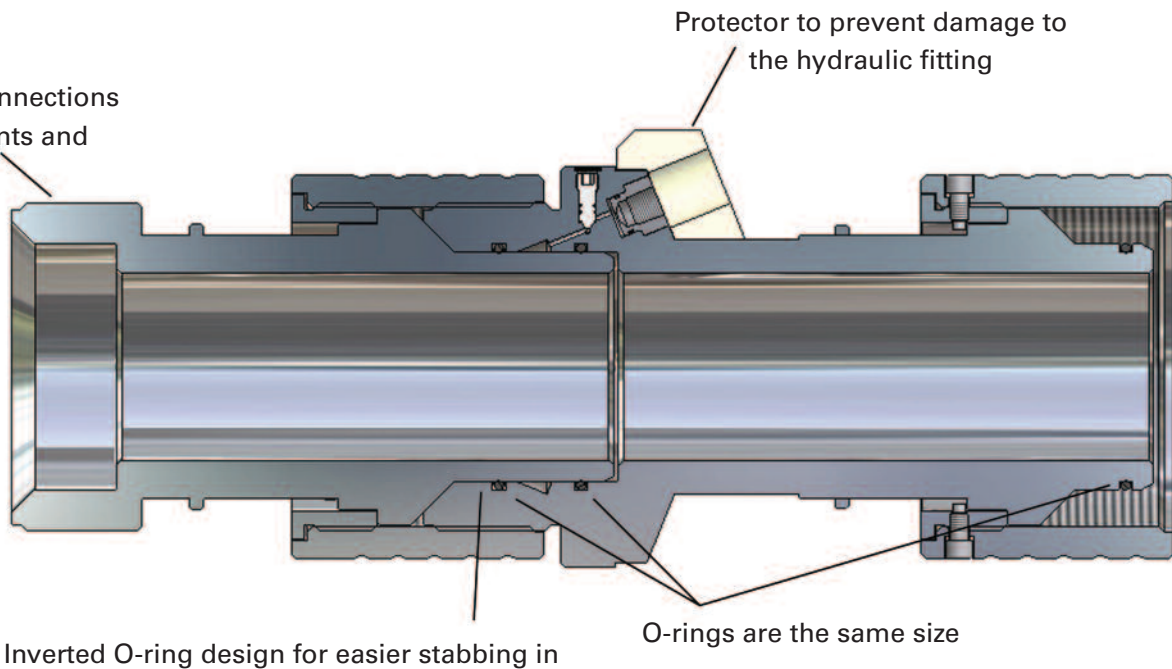

Removable Saver Sub allows a worn thread to be easily replaced